

N^o 3021



A.D. 1901

Date of Application, 12th Feb., 1901

Complete Specification Left, 12th Nov., 1901—Accepted, 6th Feb., 1902

PROVISIONAL SPECIFICATION.

“Improvements in or relating to Lubricators”:

I, WILHELM MAYBACH, Engineer, of Cannstatt, Kingdom of Württemberg, in the Empire of Germany, do hereby declare the nature of this invention to be as follows:—

5 This invention relates to lubricators and more particularly to sight-feed lubricators in which oil is fed from the reservoir by means of a pump. Sight-feed lubricators are known in which two pumps are used one for raising the oil from the reservoir and the other for conveying it to the conduit from which it is fed to the parts to be lubricated, but in the apparatus constructed according to this invention one pump only is used for both purposes.

10 According to one method of carrying out this invention the lubricator is provided with the usual oil reservoir within which is mounted a reciprocating plunger. The operative end of the plunger slides in a barrel, one end of which communicates with the oil reservoir and also with the sight-feed chamber containing water usually employed in sight-feed lubricators. The reciprocating
15 plunger is provided with a transverse slot engaging a pin secured to an arm or its equivalent pivotted to any convenient part of the oil reservoir so that by revolving the arm the plunger may be reciprocated. At one end of the plunger is a spring which always tends to urge the plunger forward and thus to drive the oil out of the barrel within which the plunger operates. Mounted within the
20 reservoir is a worm and worm wheel driven by any convenient means. Upon the worm wheel is a pin adapted to engage the arm operatively connected with the reciprocating plunger in the manner described above.

The operation of this device is as follows:—

25 Presuming the plunger to be at the end of its in-stroke, that is at the bottom of the barrel, as the worm wheel is revolved by means of the worm the pin engages the arm in operative connection with the reciprocating plunger and carries it round with it. The rotation of the arm withdraws the plunger from the barrel against the action of its spring and during this withdrawal of the
30 plunger oil is drawn into the barrel from the oil reservoir. When the arm has reached such a position that that end of it which is engaged by the pin on the worm wheel is in line with the plunger and the centre about which the arm turns, the spring will suddenly return the plunger to its former position at the bottom of the barrel carrying the arm with it so that it takes up the normal position described before the commencement of the operation. This sudden return of the
35 plunger forces the oil from the plunger barrel, part of the expelled oil returning into the oil reservoir whilst the other part passes through a non-return valve into the sight-feed chamber.

40 The amount of oil allowed to return to the reservoir and thus the amount admitted to the sight-feed chamber, may be regulated by an adjustable needle valve or other convenient device.

The various parts being again in their normal position the pin on the worm wheel continuing to rotate will again come into contact with the arm which engages the reciprocating plunger and revolving the same will again withdraw the plunger from the barrel and repeat the cycle of operations.

45 In addition to the means of regulation described, the regulation may be effected by varying the strength of the spring by which the plunger is returned

[Price 8d.]

Maybach's Improvements in or relating to Lubricators.

to its normal position in the barrel, or the length of stroke given to the plunger may be varied.

Obviously the one pump may be used to supply oil to several sight-feed chambers simultaneously, each chamber being provided with its own non-return valve. 5

In some cases it may be preferred to dispense with the sight-feed device using the reciprocating plunger as a pump to inject oil directly into the part or parts to be lubricated. The amount of oil injected by this means at each movement of the plunger may be indicated by a scale placed in proximity to the adjustable needle valve or some part connected therewith so that the position of the needle valve may be read from the scale. 10

Dated this 12th day of February, 1901.

BOULT, WADE & KILBURN,
Agents for the Applicant.

COMPLETE SPECIFICATION. 15

Improvements in or relating to Lubricators

I, WILHELM MAYBACH, Engineer, of Cannstatt, Kingdom of Württemberg, in the Empire of Germany, do hereby declare the nature of this invention and in what manner the same is to be performed, to be particularly described and ascertained in and by the following statement:— 20

This invention relates to lubricators and more particularly to sight-feed lubricators to which oil is fed from the reservoir by means of a pump. Sight-feed lubricators are known in which two pumps are used one for raising the oil from the reservoir and the other for conveying it to the conduit from which it is fed to the parts to be lubricated, but in the apparatus constructed according to this invention one pump only is used for both purposes. 25

According to one method of carrying out this invention the lubricator is provided with the usual oil reservoir within which is mounted a reciprocating plunger. The operative end of the plunger slides in a barrel, one end of which communicates with the oil reservoir and also with the sight-feed chamber containing water usually employed in sight-feed lubricators. The reciprocating plunger is provided with a transverse slot engaging a pin secured to an arm or its equivalent pivoted to any convenient part of the oil reservoir so that by revolving the arm the plunger may be reciprocated. At one end of the plunger is a spring which always tends to urge the plunger forward and thus to drive the oil out of the barrel within which the plunger operates. Mounted within the reservoir is a worm and worm wheel driven by any convenient means. Upon the worm wheel is a pin adapted to engage the arm operatively connected with the reciprocating plunger in the manner described above. 30 35

The operation of this device is as follows:— 40

Presuming the plunger to be at the end of its in-stroke, that is at the bottom of the barrel, as the worm wheel is revolved by means of the worm the pin engages the arm in operative connection with the reciprocating plunger and carries it round with it. The rotation of the arm withdraws the plunger from the barrel against the action of its spring and during this withdrawal of the plunger oil is drawn into the barrel from the oil reservoir. When the arm has reached such a position that that end of it which is engaged by the pin on the worm wheel is in line with the plunger and the centre about which the arm turns, the spring will suddenly return the plunger to its former position at the bottom of the barrel carrying the arm with it so that it takes up the normal position described before the commencement of the operation. This sudden return of the 45 50

Maybach's Improvements in or relating to Lubricators.

plunger forces the oil from the plunger barrel, part of the expelled oil returning into the oil reservoir whilst the other part passes through a non-return valve into the sight-feed chamber.

The amount of oil allowed to return to the reservoir and thus the amount admitted to the sight-feed chamber, may be regulated by an adjustable needle valve or other convenient device.

The various parts being again in their normal position the pin on the worm wheel continuing to rotate will again come into contact with the arm which engages the reciprocating plunger and revolving the same will again withdraw the plunger from the barrel and repeat the cycle of operations.

In addition to the means of regulation described, the regulation may be effected by varying the strength of the spring by which the plunger is returned to its normal position in the barrel, or the length of stroke given to the plunger may be varied.

In some cases it may be preferred to dispense with the sight-feed device using the reciprocating plunger as a pump to inject oil directly into the part or parts to be lubricated. The amount of oil injected by this means at each movement of the plunger may be indicated by a scale placed in proximity to the adjustable needle valve or some part connected therewith so that the position of the needle valve may be read from the scale.

In the accompanying drawings,

Figure 1 is a longitudinal vertical section of a lubricating device constructed according to this invention;

Figure 2 is an underside view of a portion of the apparatus in section on the line X—X of Figure 1; and

Figure 3 is a longitudinal vertical section of a modified construction of lubricator.

Like letters indicate like parts throughout the drawings.

The mechanism for operating the pump illustrated in the drawings is of known construction and comprises a crank disc *a* free to rotate in a bearing *a*¹. The crank disc is provided with a pin *b* which engages a sliding block *b*¹ free to reciprocate in a slot *c* formed in the pump plunger *d*. Beneath the crank disc *a* is mounted a worm wheel *f* carrying a pin *e*, the worm wheel being driven by a worm *g* to which motive power may be applied by any convenient means. On the crank disc *a* is a projection *h* adapted to be engaged by the pin *e* on the wheel *f* as the latter rotates carrying with it the pin and as the crank disc is rotated the plunger is moved backwards or forwards by the pin *b*. The plunger *d* is spring controlled, a spiral spring *i* operating between any convenient fixed part and the plunger rod so that as the disc *a* is rotated in such a manner as to withdraw the plunger rod from its cylinder *d*¹ the spring *i* is compressed until the parts arrive in the position shown in Figures 1 and 2. At this point it will be seen that a very little further movement of the pin *e* in the direction indicated by the arrow Figure 2, will carry the pin *b* out of alignment with the direct action of the spring *i* so that the plunger rod will be shot forward by the spring carrying with it the disc *a*. The pin *e* will then follow the projection *h* which has been moved from it and engaging the same at the end of another half revolution will carry it back slowly to the position shown in Figure 2, when the plunger will again be shot forward by the spring.

By means of the mechanism described the plunger *d* has a quick advance and slow return movement, the former of which is used to discharge lubricant through the feed pipe to the parts to be lubricated, whilst the latter movement is employed to draw the lubricant from the reservoir *k* into the barrel *d*¹.

The barrel *d*¹ communicates with the reservoir *k*, in which the mechanism for operating the pump is conveniently mounted, by means of a pipe *l* controlled by an adjustable valve *m*. The valve *m* in this case takes the form of a screw-threaded pin which may be advanced or withdrawn so as to more or less close the mouth of the pipe *l*.

Maybach's Improvements in or relating to Lubricators.

Communicating also with the barrel d^1 is a second pipe n controlled by a ball valve communicating with a nozzle r , within a sight feed chamber g . The sight feed chamber may be of any convenient construction and is illustrated in the drawings as comprising a glass cylinder provided with top and bottom caps suitably arranged to receive the pipe n and a feed pipe s by which lubricant is conveyed to the parts to be lubricated. 5

Between the base of the nozzle r and the pipe n a chamber o is preferably provided, the interior of which communicates by orifices p with the interior of the sight feed chamber g .

The operation of this device is as follows:—

The sight feed chamber g is filled with water and the pump set in operation. As the plunger d is slowly withdrawn from the barrel d^1 oil is drawn from the reservoir k by the pipe l into the barrel. Upon the quick advance movement of the plunger d the oil drawn into the barrel raises the ball of the valve in the pipe n and passes through the chamber o into the nozzle r . As the lubricant passes through the chamber o part of the water contained therein is expelled by the orifices p into the chamber g . The oil escapes from the upper end of the nozzle r and rises to the feed pipe s until the latter is filled, when every additional charge of oil driven by the pump into the nozzle will cause a pulsation of the oil at the opposite end of the feed pipe s so that a certain quantity is projected from the feed pipe with considerable force into the parts to be lubricated. 10 15 20

Each advance stroke of the plunger d in addition to driving oil through the pipe n will return part of the oil by the pipe l to the reservoir k and the amount thus returned may be regulated by adjusting the valve m which thus becomes a regulating device by which the amount of lubricant discharged from the feed pipe may be accurately adjusted. 25

The nozzle r is conveniently made of transparent material and carries a scale so that the amount of oil collecting therein may be ascertained for the purpose of reading the quantity of oil discharged by each operation of the plunger.

If preferred the chamber o may be dispensed with and the nozzle r connected direct to the pipe n in which case it need not be transparent as it will always remain charged with oil, the nozzle serving in this case only to indicate that the pump is in operation by the discharge of oil from it appearing in its passage through the water in the sight feed chamber g . 30

The amount of oil or lubricant discharged by each pulsation of the pump may be further regulated by varying the stroke of the plunger d , as for instance by making the pin b adjustable upon the crank disc a so that it may be moved nearer to or further from the centre of the latter; also a further regulation may be obtained by adjusting the tension of the spring i . 35

In practice it has been found that the water in the sight feed chamber g becomes mixed with the oil if the pump is worked continuously for any length of time so that a modification of this device is sometimes employed in which the water is dispensed with. Figure 3 illustrates a modification of this kind. The pipe n in this construction of apparatus communicates direct with the feed pipe s and also communicates with a nozzle r^1 mounted in a chamber g^1 , conveniently constructed of glass or provided with transparent portions in its walls through which the nozzle may be seen. A pipe t communicates with the base of the chamber g^1 and the reservoir k . 40 45

The operation of this device is similar to that of the other construction:—

The advance movement of the plunger d forces oil through the valve of the pipe n (a mushroom valve being employed in this case) so that a certain amount of lubricant is discharged from the feed pipe s . The amount of oil discharged is regulated as before by adjusting the valve m or other parts of the mechanism as described and at every discharge from the cylinder d^1 into the pipe n a small quantity of oil will be forced through the nozzle r^1 and projected into the chamber g^1 . This discharge of oil into the chamber g^1 is merely to indicate that the pump is in operation and as the oil collects in the chamber g^1 it is conveyed back 55

Maybach's Improvements in or relating to Lubricators.

by the pipe *t* to the reservoir *k*. The nozzle *r*¹ may be provided with a ball or other non return valve, if desired.

Although both of the above lubricators have been described as provided with sight feed devices, the sight feed apparatus may, if desired, be dispensed with
5 without departing from the spirit of the invention which has particular reference to the method by which the amount of oil discharged from the feed pipe may be regulated.

In place of the transparent nozzle *r* for indicating the amount of oil discharged at each stroke of the plunger *d* the screw valve *m* may be provided with a scale
10 and pointer so that its position may indicate the relative proportions of oil forced through the pipe *n* or returned to the reservoir *k* at each stroke of the plunger.

Obviously the one pump may be used to supply oil to several sight feed chambers simultaneously or to force oil simultaneously through several feed pipes each provided with its own non-return valve between it and the pump cylinder.

15 If desired the pump plunger *d* may be reciprocated by a quick movement in both directions instead of a slow return and quick advance action and a non-return valve communicating with the passage *l*, may be provided so that lubricant may be readily admitted to the barrel *d*¹. Any convenient mechanism may be employed for giving a quick advance and return movement to the pump plunger,
20 the mechanism being timed to operate at the required intervals.

Having now particularly described and ascertained the nature of my said invention and in what manner the same is to be performed I declare that what I claim is:—

1. In a lubricating device the combination with a pump plunger having a slow
25 return and a quick advance stroke of a pipe serving both as a supply and as a bye-pass and having in it an adjustable valve substantially as and for the purpose described.

2. In a lubricating device the combination with the supply pipe *l* for the pump controlled by an adjustable valve of a sight feed chamber *q* having within it a
30 nozzle such as *r*¹ communicating at its base with the pump barrel by a valve controlled orifice and with the chamber *q* by orifices such as *p* substantially as and for the purpose described.

3. In a lubricating device having a bye-pass supply such as *l*, *m*, the combination with a feed pipe through which lubricant is intermittently discharged by
35 a pump of a chamber such as *q*¹ having transparent walls or wall portions and communicating with the feed pipe substantially as and for the purpose described.

4. The complete lubricating device substantially as described and illustrated in Figures 1 and 2 or Figure 3 of the accompanying drawings.

Dated this 12th day of Novr 1901.

40

BOULT, WADE & KILBURN,
Agents for the Applicant.

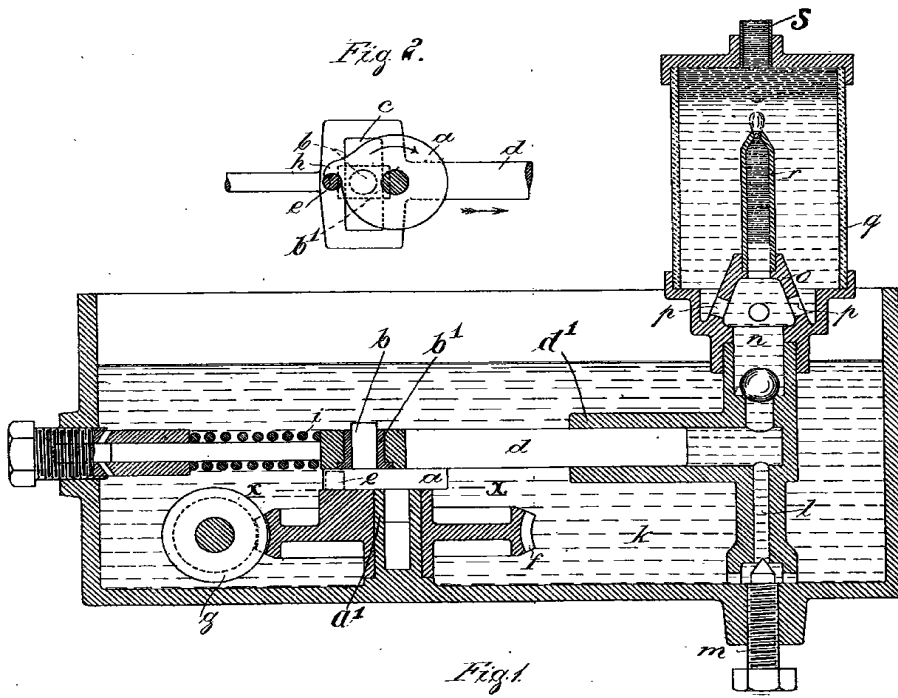

[This drawing is a reproduction of the Original unenlarged scale]

Fig. 2.

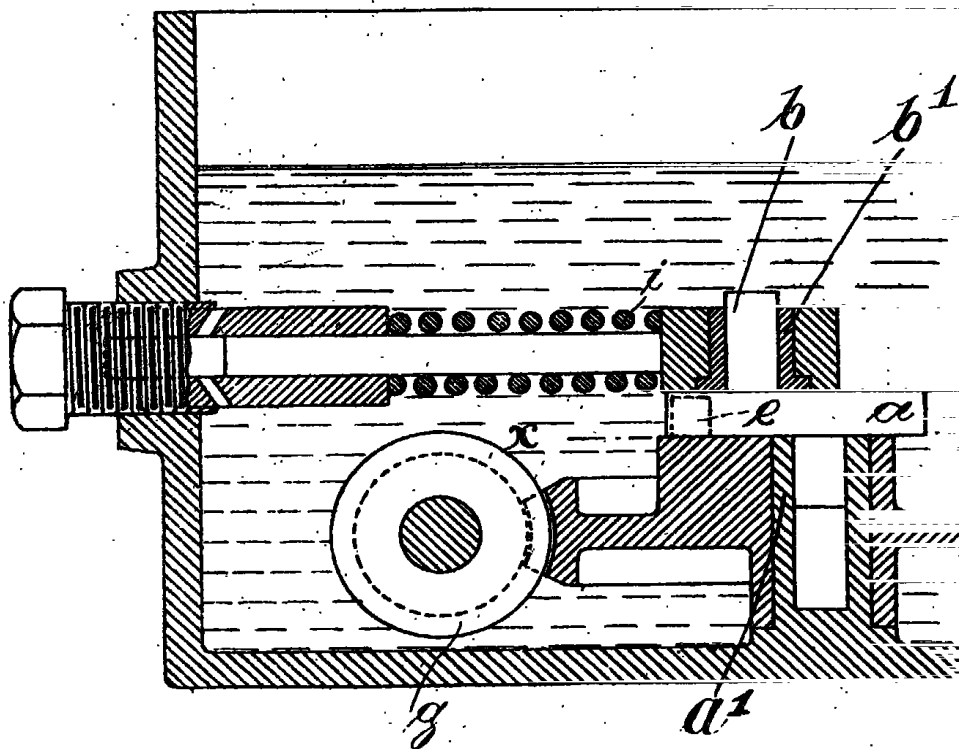
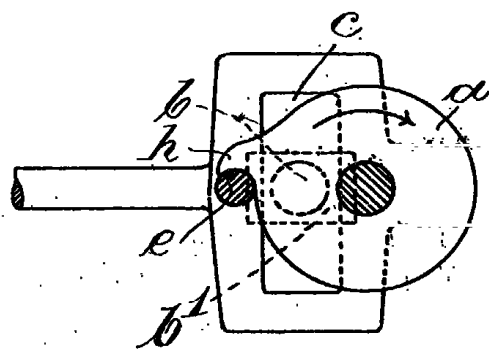

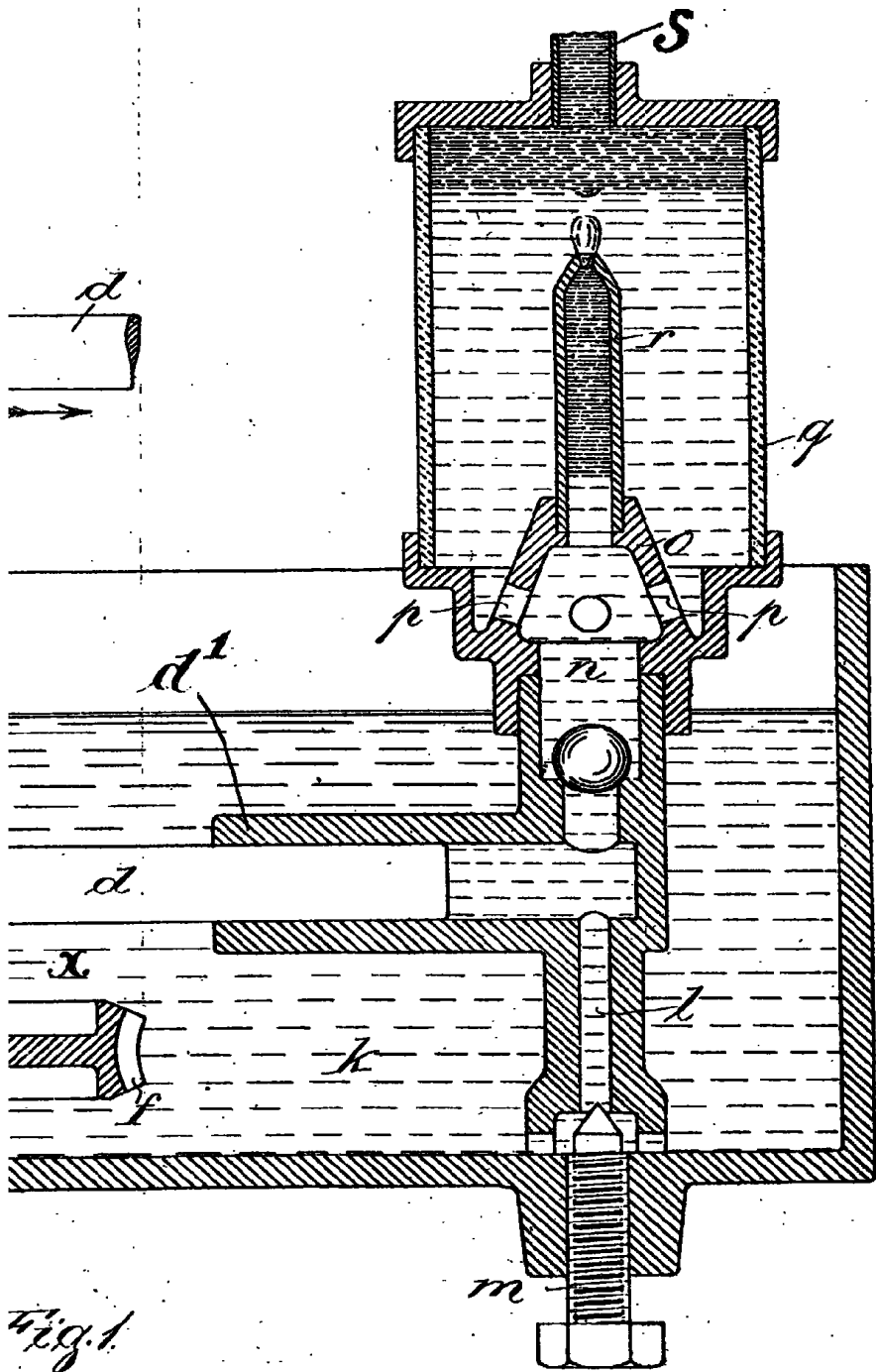
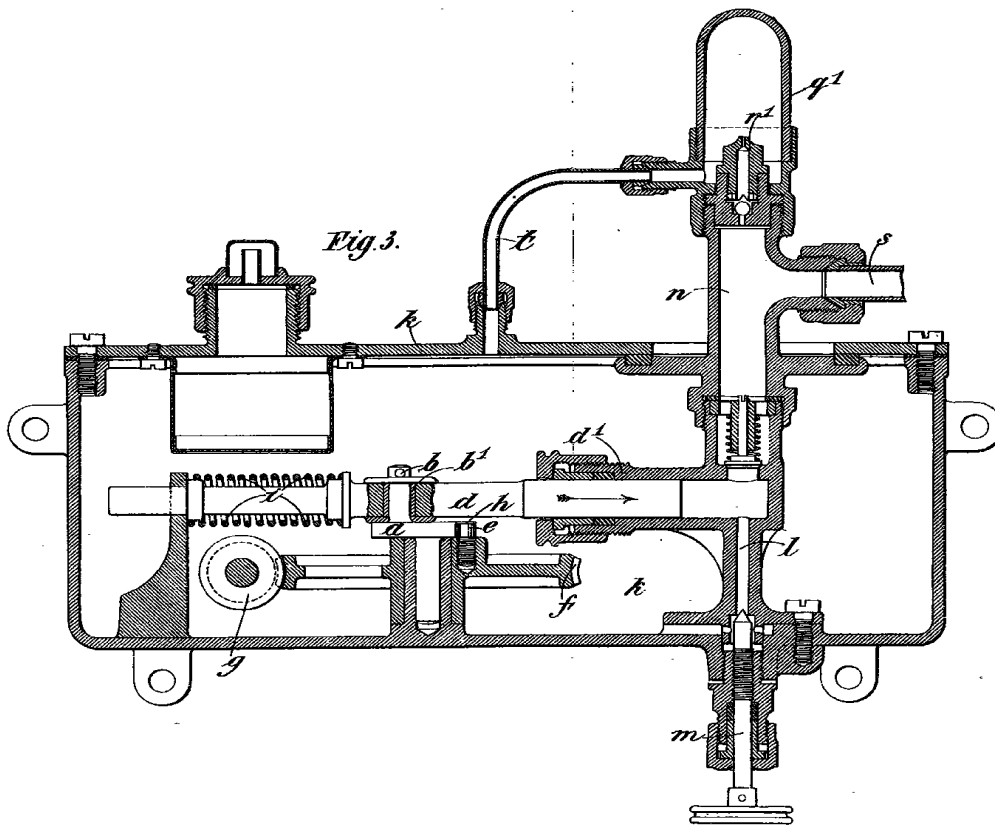
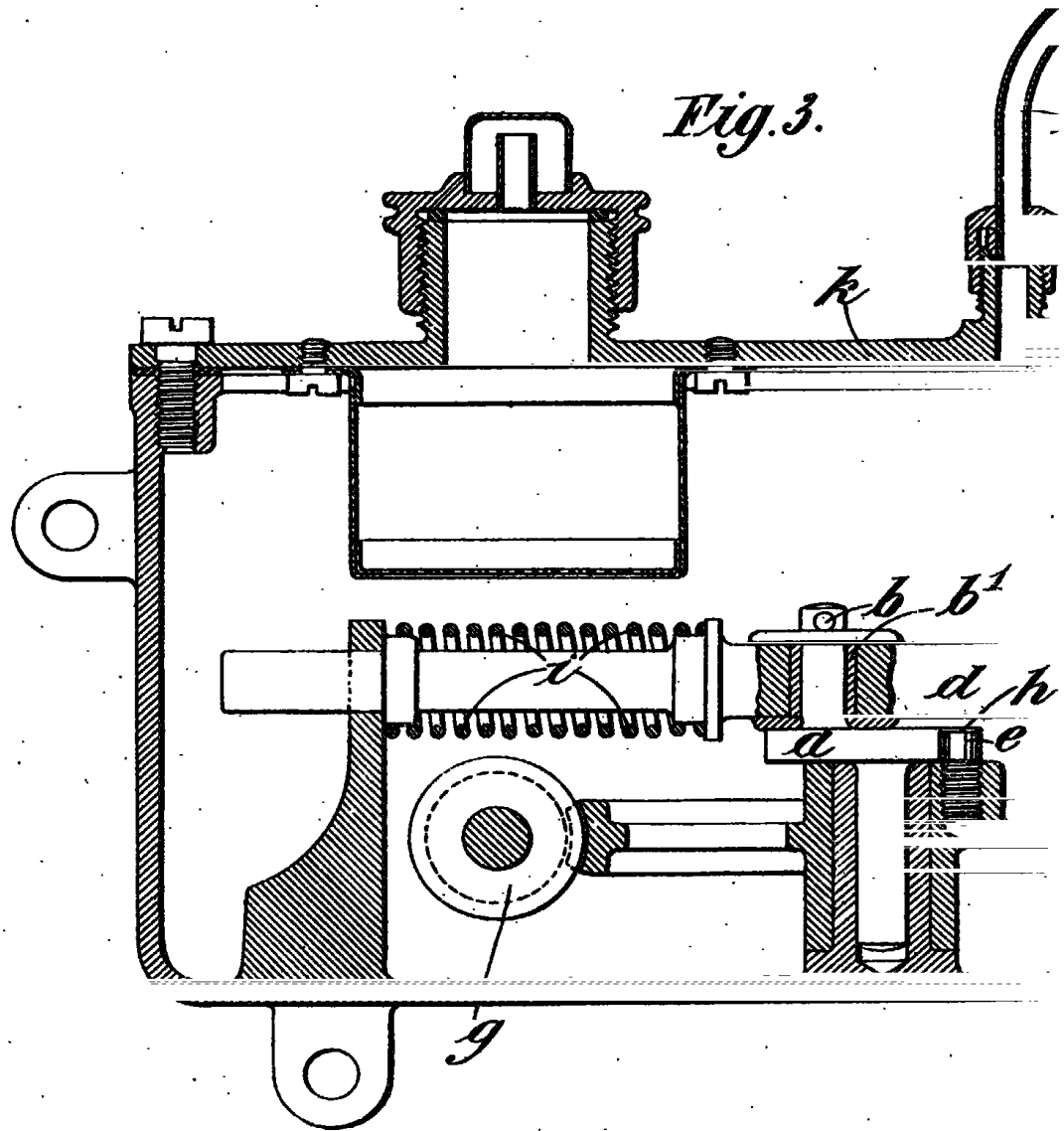

Fig. 1.

[This Drawing is a reproduction of the Original on a reduced scale.]



[This drawing is a reproduction of the Original and is not to be scaled.]



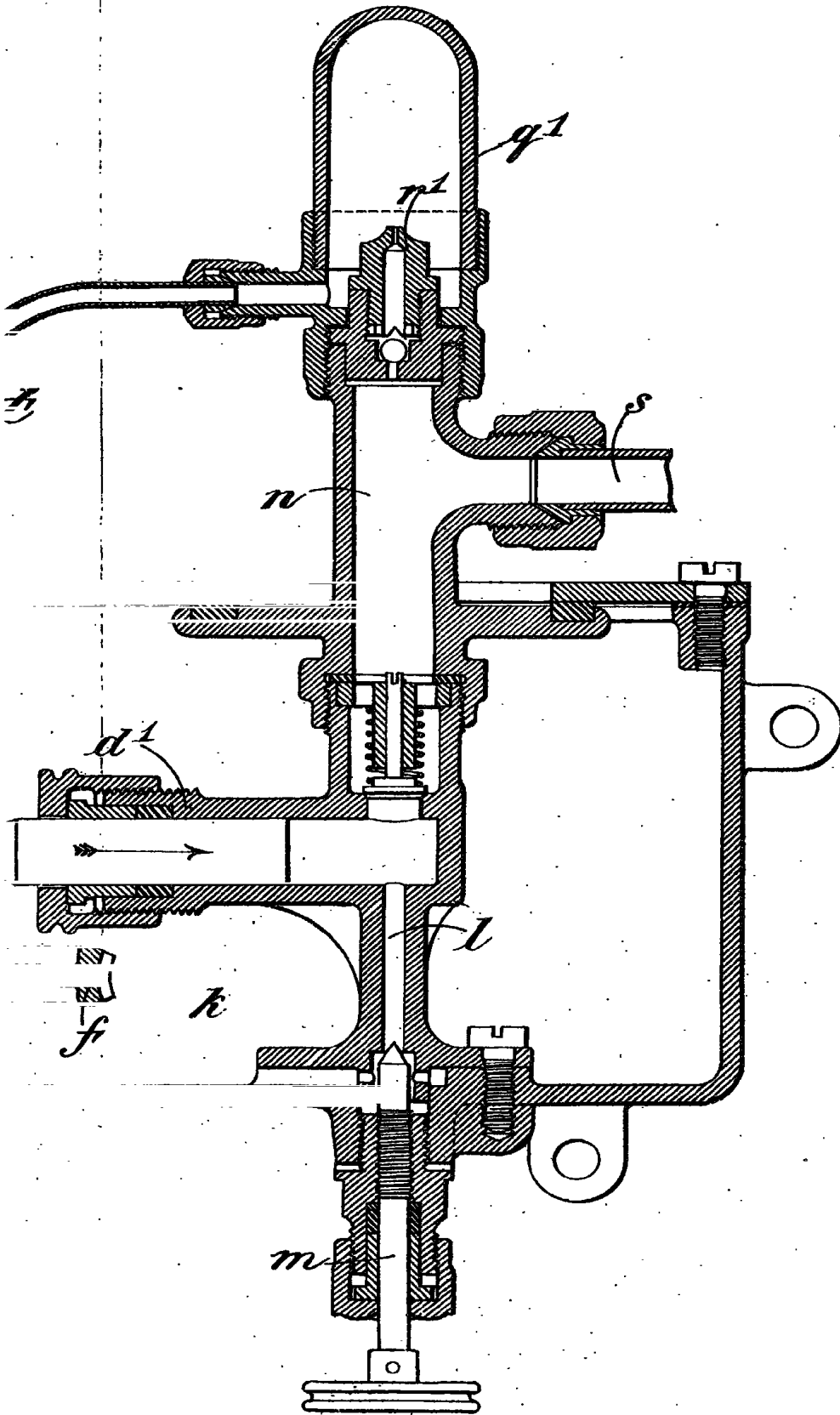

[This Drawing is a reproduction of the Original on a reduced scale]